

LèPRESSO



LePresso

Coffee Machine 20 Bar Powerful Pressure Pump with Capsule Filter and Funnel

SKU: LP20BCMCFBK

Table of Contents



Safety Precautions	2
Warning	4
Specifications	5
Schematic View	5
Indicator Guideline	6
Setup Guide	6
Prepare the Unit	7
Select the Correct Cup	7
Select the Correct Coffee	8
Filling the Device	9
Filter Insertion	10
Coffee Filling Procedure	10
Placing the Funnel	11
Placing the Cup	12
Powering ON	12
Sleep Mode	12
Froth Guide	13
Coffee Preparation	13
Descaling	15
Maintenance	16
Deliming	19
Instructions for Use	20
Troubleshooting	21
Disposal	22
Warranty	23
Contact Us	23

Before installing and using the product, please carefully read this User Manual to guarantee correct usage and keep it secure for future reference.

Safety Precautions

- 1.** Please do not place the appliance in a cabinet when in use.
- 2.** Ensure the voltage of your outlet matches the voltage specified on the appliance's rating label.
- 3.** Avoid fire, electric shock, and personal injury by not immersing the cord, plug, or appliance itself in water or any other liquid.
- 4.** Always supervise children closely when they are near the appliance.
- 5.** Disconnect the appliance from the outlet when not in use, before attaching or removing parts, and prior to cleaning. Allow the appliance to cool before cleaning.
- 6.** Do not use the appliance if it has a damaged cord or plug, if it malfunctions, or if it has been damaged in any way. Return the appliance to an authorized service facility for inspection, repair, or adjustment.
- 7.** Using accessories not recommended by the manufacturer may result in fire, electric shock, or injury.
- 8.** To disconnect the appliance, turn all controls to the off position and then remove the plug from the wall outlet.
- 9.** Avoid contact with hot surfaces by using handles or knobs.
- 10.** The appliance is not intended for outdoor use or for commercial purposes.
- 11.** Prevent the cord from hanging over the edge of a table or counter, or from touching hot surfaces.
- 12.** Operate the appliance on a hard, flat, level surface to ensure proper air circulation and prevent overheating.
- 13.** Always secure the water reservoir by placing it tightly back into the unit with its lid closed and ensuring it is filled to at least the minimum required level before powering on the appliance.

- 14.** Do not remove the porta-filter while the coffee is brewing. Ensure the indicator lights show that it is safe to do so before removing the porta-filter for additional coffee preparation. Exercise caution due to hot metal parts and hold the porta-filter by the handle, using the filter retention clip to dispose of the coffee grounds. Extra care is needed when moving the appliance containing hot liquids.
- 15.** The water reservoir should not be removed until the appliance has been turned off and is completely cool.
- 16.** The appliance should not be operated with any external timer or separate remote-control system.
- 17.** Children aged 8 years and older, and persons with reduced physical, sensory, or mental capabilities may use the appliance if they have been adequately supervised and instructed on safe operation, fully understanding the associated risks. Children must not play with the appliance, and those under 8 years old should not perform cleaning or maintenance tasks.
- 18.** Ensure the appliance and its power cord are kept out of the reach of children under 8 years of age.
- 19.** Before disassembling any parts or accessories, verify that the three indicator lights are illuminated, switch the power to the off position "0", and unplug the appliance.
- 20.** The porta-filter must not be removed at any point during the brewing process to avoid accidents.
- 21.** Exercise extreme caution when removing the porta-filter as it and other metal parts may be very hot. Hot water may also be present on the filter's surface. Always hold the porta-filter by its handle and use the filter retention clip to safely dispose of used coffee grounds.
- 22.** If the coffee flow is interrupted and no coffee drips out, it indicates a blocked filter. Turn off the appliance, allow it to cool, and check for a fine grind that may be causing the blockage. Refer to the "Troubleshooting" section.

- 23.** When cleaning the frothed milk dispensing tube: Place a large cup under the tube. Refill the milk reservoir with water and reattach it to the unit. Turn the control knob clockwise to the clean position  **Clean**, then press and hold the latte/clean button for three seconds to activate the cleaning function. Allow the unit to dispense water through the tube for approximately 30 seconds, then press the Latte/Clean Button once to stop the process.
- 24.** Do not place the appliance on or near a hot gas or electric burner, or inside a heated oven.
- 25.** Do not use the appliance for purposes other than those intended.
- 26.** Do not leave the appliance unattended while it is in operation.
- 27.** This appliance is intended for use in household and similar environments, such as staff kitchen areas in shops, offices, and other working environments; farmhouses; by clients in hotels, motels, and other residential environments; and in bed and breakfast type environments.
- 28.**  Never submerge the appliance in water or any other liquids. This poses a risk of electric shock.
- 29.** Retain these instructions for future reference.

Warning

To prevent possible burns or other injuries from hot steam and water, or damage to the unit, do not remove the water reservoir or the porta-filter while your espresso/cappuccino maker is brewing coffee or frothing. Ensure that the three indicator lights are activated before you attempt to remove the porta-filter for additional coffee preparation. If it is necessary to add more water or milk to the reservoirs, verify that the three lights are illuminated. Additionally, always turn off the machine by pressing the red button on the side of the unit to the off position “0”.

Specifications

Product	LePresso Coffee Machine 20 Bar Powerful Pressure Pump with Capsule Filter and Funnel
SKU	LP20BCMCFBK
Voltage	220V ~ 240V (60/50Hz)
Power	1050W ~ 1250W
Pressure	20bar
Water Tank Capacity	1.7L
Milk Tank Capacity	500mL
Temperature Control	NTC
Preheating Time	≤90s
Dimensions	274×227×300mm
Net Weight	10.04kg

Schematic View

A. Water tank cover

B. Water tank

C. Milk tank cover

D. Knob

E. Froth nozzle

F. Milk tank

G. Switch

I. Drip plate

K. Pressurized funnel ASM

H. Drip tray

J. Drip tray bracket

L. Top cover





Indicator Guideline

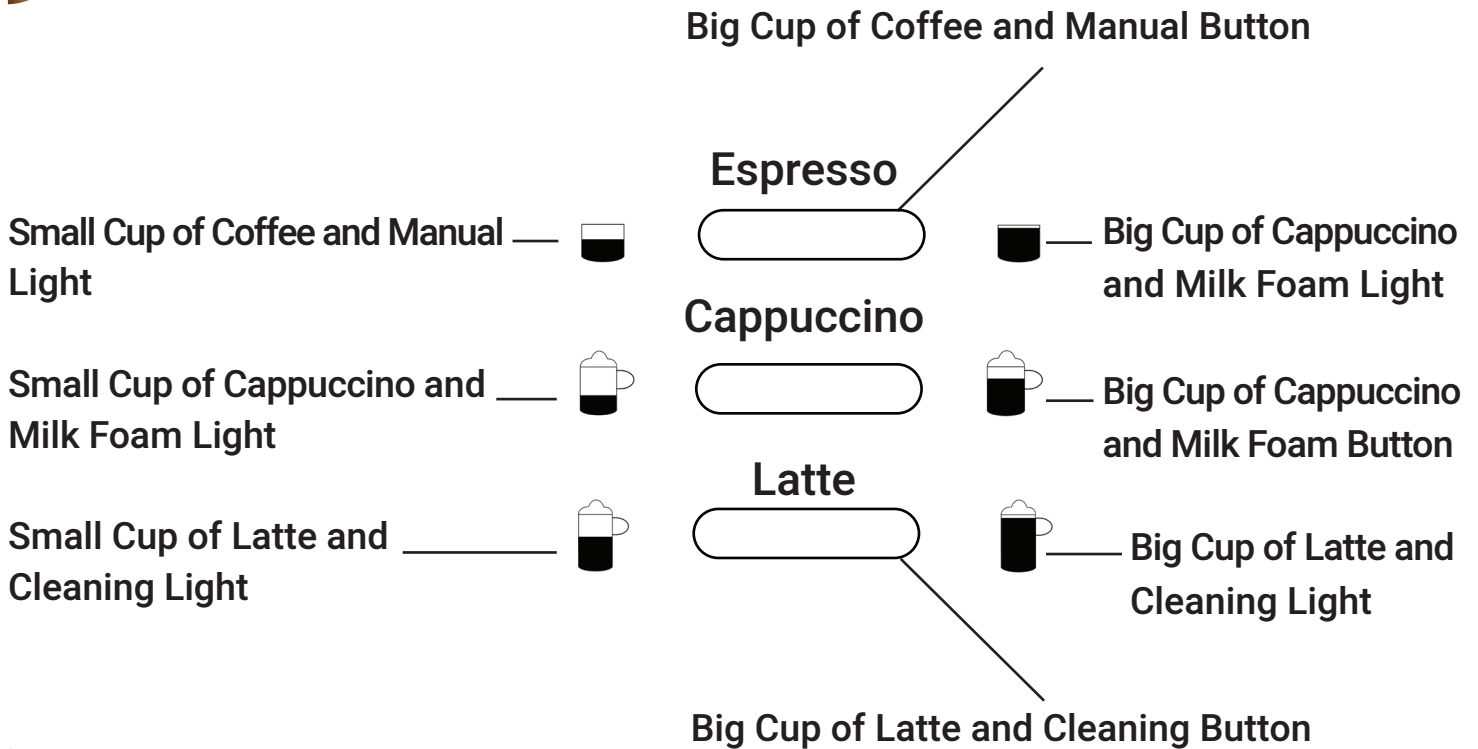

Setup Guide

Cleaning and priming the unit prior to first use is crucial. Please refer to the “Description of the Appliance” section to become familiar with the product and identify all parts.

1. Ensure the unit is turned off (“0”) by pressing the switch located on the side of the unit. Confirm that it is unplugged from the electrical outlet.
2. Remove any stickers and labels from the unit.
3. Begin by removing and then washing the water tank, the milk tank, the two filters, the pressurized funnel, and the coffee scoop in a mixture of mild detergent and water. Rinse each thoroughly and return them to the unit.

4. Consult the instructions in the “Filter Insertion” section before placing or removing the pressurized filter from the unit.
5. To clean the inside of the appliance, adhere to the steps listed in the “Preparing Cappuccino” section, using only water in both reservoirs and ensuring no coffee is in the filter. Do not immerse the appliance in water or attempt to reach any of its internal parts.

Note: For consistent performance, clean your unit after every use.







Prepare the Unit

To prime the unit, run the steam cycle for 90 seconds by following these steps:

1. Fill the water tank to a level between the “Min” and “Max” indicators.
2. Fill the milk tank with water up to the level between the “Min” and “Max” indicators.
3. Choose a filter and install it in the pressurized funnel assembly. Ensure it is securely locked in place and position a cup under the frothed milk dispensing tube to capture the output.
4. Connect the appliance to the appropriate power outlet.
5. Turn the unit on by switching it to the “I” position.
6. The six control panel lights will begin to blink. Once they stabilize, press the cappuccino button  twice.
7. After this process, the lights on the control panel will remain illuminated, indicating that the unit has been primed and is ready for use.

Select the Correct Cup

Before preparing your beverage, ensure you choose the appropriate cup size as outlined in the table below:

Beverage Type Ratio				
Espresso	Single 	Double 	60ml	119ml
Cappuccino	Single 	Double 	178ml	355ml
Latte	Single 	Double 	296ml	474ml

Select the Correct Coffee

1. Coffee

The coffee should be freshly ground and dark roasted, ideally suited for espresso. Consider using a French or Italian roast. Pre-ground coffee maintains its flavor for approximately 7 to 8 days if stored in an airtight container in a cool, dark area. Avoid storing in a refrigerator or freezer. For optimal freshness, it is recommended to grind whole beans just before use. Coffee stored in an airtight container can retain its flavor for up to four weeks.

2. Grind

This is a critical step in the espresso-making process, especially when grinding your own coffee, which requires skill and practice. The coffee must be ground to a fine consistency. The ideal grind should resemble the texture of table salt. If the grind is too fine, the water will not properly flow through the coffee even under pressure, resembling a powdery texture similar to flour when felt between the fingers. Conversely, if the grind is too coarse, the water will pass through the coffee too quickly, preventing a thorough extraction of flavors. It is essential to use a high-quality grinder to achieve a uniform grind for the best results.

Important Note: Avoid using sugar-roasted ground coffee or sugar-roasted coffee beans as they can cause filter clogging and damage to the appliance. In the event of accidental use, discontinue operation and seek maintenance at the nearest service center. Periodic descaling is recommended to maintain the appliance's performance. Please contact our service centers for further information on this procedure.

Filling the Device

A. Filling the Water Tank

1. To fill the water tank, you can either use a jug to pour water into it or remove the tank from the unit to fill it under a tap.

Note: If you choose to remove the tank, ensure you replace it securely afterwards.

2. Fill the tank with the desired amount of water, making sure the water level is between the "MIN" and "MAX" indicators on the tank.

Note: Do not use warm or hot water to fill the water reservoir.

3. Securely close the water reservoir lid and ensure it is properly repositioned on the unit.

B. Filling the Milk Tank

1. If you intend to prepare a cappuccino or latte, first remove the milk tank from the unit.

2. Open the lid, then pour the estimated amount of cold milk needed, ensuring the level is between the "MIN" and "MAX" indicators.

3. After filling, securely replace the milk tank in the unit.

Note: You may use any type of milk you prefer, such as whole milk, low-fat milk, organic milk, or soy milk.

C. Choose the Filter

Select the appropriate filter for use as follows:

1. For a Single Shot: Use the filter designated for a single shot of espresso if using ground coffee.
2. For a Double Shot: Use the filter designated for a double shot of espresso.

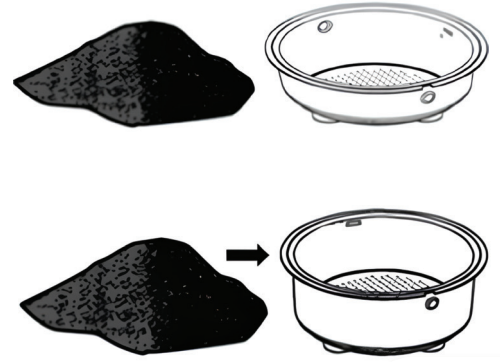

Note: The pod filter included with your unit is specifically designed to work only with the pods recommended for your model.

Filter Insertion

1. When inserting the chosen filter into the pressurized funnel assembly, ensure proper alignment by matching the notch on the filter with the groove inside the pressurized funnel assembly.
2. Rotate the filter either left or right to engage the locking mechanism, ensuring a secure fit within the pressurized funnel assembly.

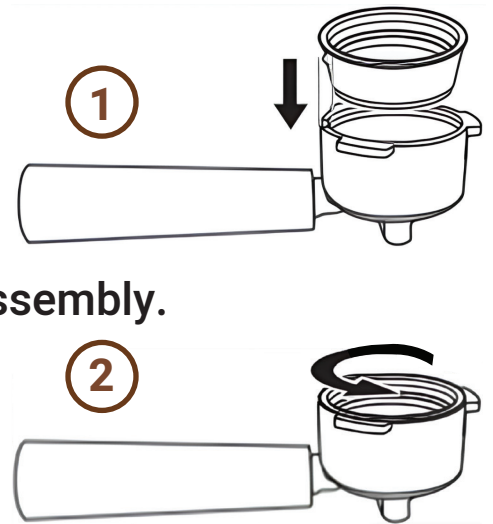

Note: To remove and clean the filter, rotate it to the left or right until the filter notch aligns with the groove inside the pressurized funnel assembly.

Warning: Exercise caution and allow the filter to cool before attempting removal. Ensure safety precautions are followed at all times.

Coffee Filling Procedure

Position the chosen filter onto the pressurized funnel assembly according to the following steps:

1. For Ground Coffee

a. Fill the filter with fresh, finely ground espresso coffee, ensuring not to overfill.

Note: The amount of ground coffee must not exceed the MAX mark.

b. Tamp down and evenly compress the coffee grounds firmly.

c. Remove any excess coffee from the rim to ensure a proper fit under the brew head.

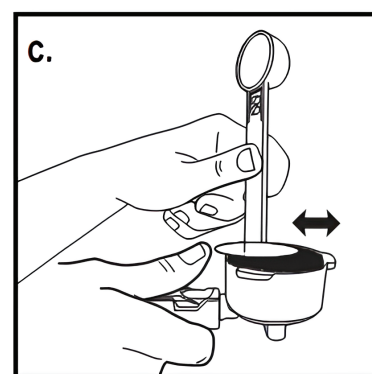
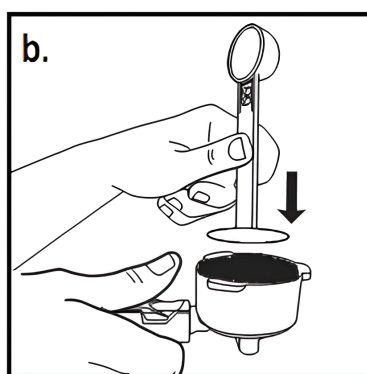
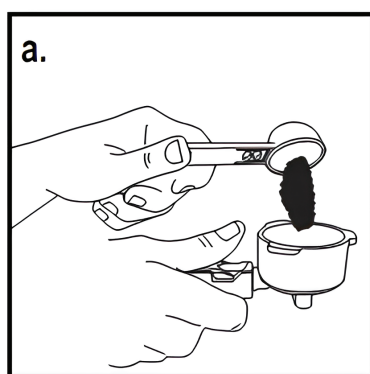

Placing the Funnel

a. Place the pressurized funnel assembly under the brew head and attach it by first moving the retainer clip backward.

b. Align the handle with the open lock icon “” on the unit and insert it into the groove.

c. Slowly rotate the handle to the right until the retention clip aligns with the closed lock symbol “” on the unit.

Note: Exercise caution as the frothing tube may be very hot.

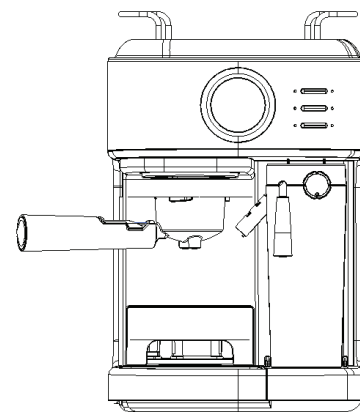
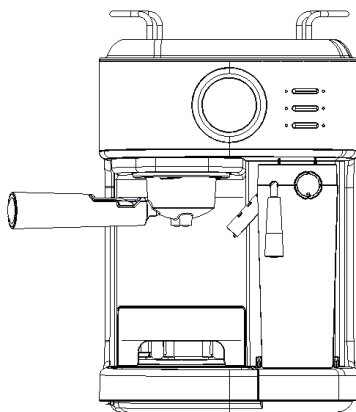
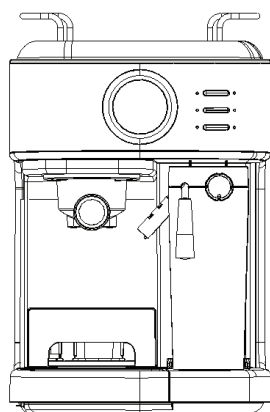

Placing the Cup

- a. If using a small cup for brewing espresso, pull out the drip tray bracket.
- b. If brewing cappuccino with a larger cup, retain the drip tray bracket within its compartment.
- c. Similarly, keep the drip tray bracket inside its compartment when brewing latte with a larger cup.

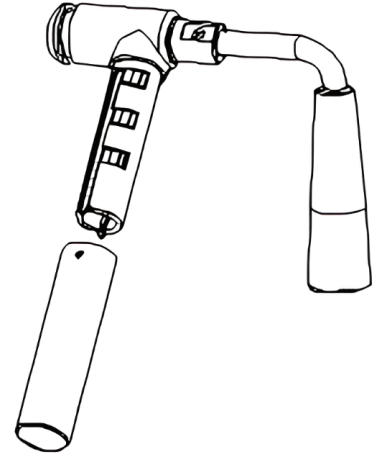

Caution: When brewing cappuccino or latte, ensure proper adjustment of the frothing tube lever to position the milk dispensing tube inside the cup. Additionally, adjust the length of the frothed milk dispensing tube by locking it into different positions on the frothing tube lever to accommodate various cup sizes. Clean the frothing tube by rotating it out and fixing it securely.

Powering ON

- a. Ensure that the unit is properly plugged in.
- b. Turn the unit on by selecting the "I" setting.
- c. The six control panel lights will begin blinking as the unit heats up and will remain so until the water reaches the ideal temperature.
- d. Once all six lights are solid, the unit is ready for use.

Sleep Mode

If there is no activity within 15 minutes, the unit will enter sleep mode. You can awaken the unit by pressing any button.

Froth Guide

1. Preparation

- a. The unit offers the option to prepare froth milk separately.
- b. Press and hold the Cappuccino Button for 3 seconds if you desire more foam in your beverage or wish to prepare froth milk for other beverages like macchiatos, hot chocolate, Tea lattes, etc.
- c. To stop, press the Cappuccino Button once more.

2. After Use

Once you've finished preparing your milk-based beverage, you can either store the unit's milk reservoir directly in the refrigerator for future use or dispose of any remaining milk.





Coffee Preparation



1. Espresso Preparation

Introduction

A distinctive coffee brewing method where hot water is pushed through finely ground coffee. Popular in Europe, it offers a richer, fuller-bodied brew compared to regular drip coffee. Typically served in 44ml to 59ml (1.5oz. to 2oz.) portions, usually in demitasse cups.

Preparation

- a. Press the coffee button once ( illuminates) to brew a single cup of coffee.
- b. Press the coffee button twice ( illuminates) to brew a double cup of coffee.
- c. Press and hold the coffee button for 3 seconds ( and  illuminates simultaneously) to brew a large cup of coffee. When the desired amount of coffee is reached, press any button to stop the process.

d. The unit is capable of brewing espresso according to your preferences and can automatically stop brewing when the  and  lights become solid, indicating completion of the process.

Warning: After brewing, do not immediately remove the filter. Wait for 10 seconds before proceeding.



2. Cappuccino Preparation

Introduction

A beverage comprised of approximately equal parts espresso, steamed milk, and frothed milk.

Preparation

a. Before brewing cappuccino, adjust the froth control knob to the middle position.

b. Customize the quantity of the milk to your preference by turning the Froth Control Knob to the right “” for more froth or to the left “” for less froth.

Note: The froth intensity can be adjusted during the brewing cycle.

c. Press the Cappuccino Button once to brew a small cup of cappuccino.

d. Press the Cappuccino Button twice to brew a large cup of cappuccino.

e. The unit will commence brewing the cappuccino based on your chosen setting.

3. Latte Preparation

Introduction

A beverage consisting of approximately one-quarter espresso and three-quarters steamed milk.

Preparation

- a.** Before preparing your latte, customize the quantity of frothed milk to your liking by adjusting the Froth Control Knob.
- b.** Turn it to the right “☉☉” for more froth or to the left “☉” for less froth.
- c.** Press the Latte Button once to brew a small cup of latte.
- d.** Press the Latte Button twice to brew a large cup of latte.

Normal Froth

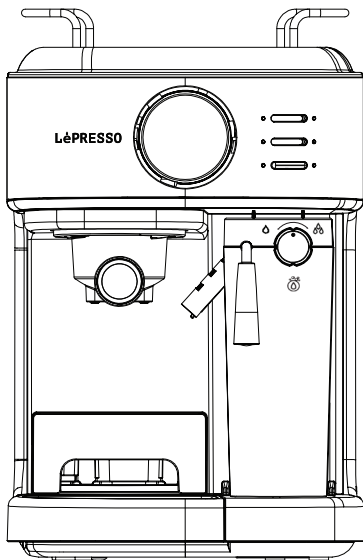

Less Froth

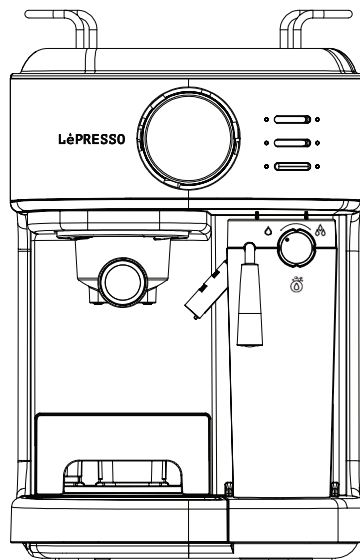

More Froth

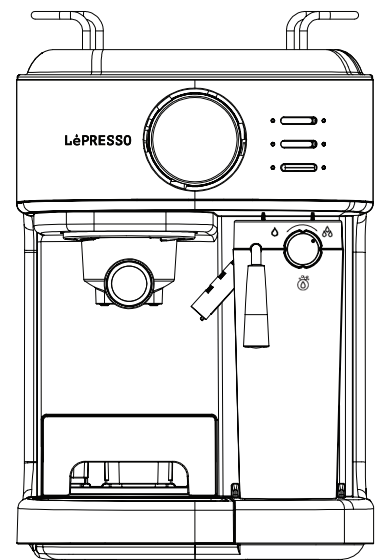

Descaling

When the milk reservoir is in place, the appliance will prompt the user to descale by flashing six indicators alternately. To initiate descaling, fill the water tank with 600ml of clean water and dedicated descaling solution. Press the Espresso and Latte buttons simultaneously, and the appliance will enter descaling mode automatically. During this process, the six indicators will flash alternately at a slow pace. After approximately half an hour of operation, the indicators will flash alternately quickly, signaling the user to empty the water tank. Refill the tank with 600ml of clean water, then press the Espresso and Latte buttons simultaneously to resume descaling. Once again, the indicators will flash alternately slowly until the process is complete, at which point the appliance will return to standby mode.

Note:

- 1.** You can activate any function by pressing its corresponding button when the appliance prompts you to descale. The appliance will continue to remind you to descale even after completing the selected function.
- 2.** The descaling process can be halted at any time by pressing any button. However, the appliance will continue to remind you to descale until the entire descaling process is completed and it returns to normal standby mode.

Maintenance

A. Cleaning the Froth Tube

Even though you can store the milk reservoir with leftover milk in the refrigerator, it's essential to clean the reservoir and frothing tube regularly to prevent clogging and residue buildup. To clean the milk reservoir, follow these steps:

- 1.** Remove the milk reservoir from the unit.
- 2.** Take off the reservoir lid.
- 3.** Detach the steam tube connector by rotating it; clean it with tap water and reattach it to the milk reservoir lid by rotating.
- 4.** While cleaning the milk reservoir, open the silicone sheet (do not pull it out) and wash it with tap water. After cleaning, replace the silicone sheet.
- 5.** Empty any remaining milk and thoroughly rinse and wash the milk reservoir and lid with warm soapy water. Avoid abrasive cleaners and scouring pads, as they can scratch the finish. The milk reservoir is dishwasher safe (top rack), but do not place the lid in the dishwasher.
- 6.** Position a large empty cup beneath the frothing tube.
- 7.** Turn the Froth Control Knob clockwise to the "Clean" position () , then press and hold the Latte/Clean button for 3 seconds before releasing it to activate the cleaning function. The unit will begin releasing steam

through the frothing tube; allow it to run until no milk is visible in the cup. Press the Latte/Clean button once to stop the process when finished.

8. Dispose of any water remaining in the milk reservoir and return it to the unit.

Note: To disassemble the milk reservoir, slightly raise it and then pull it out.

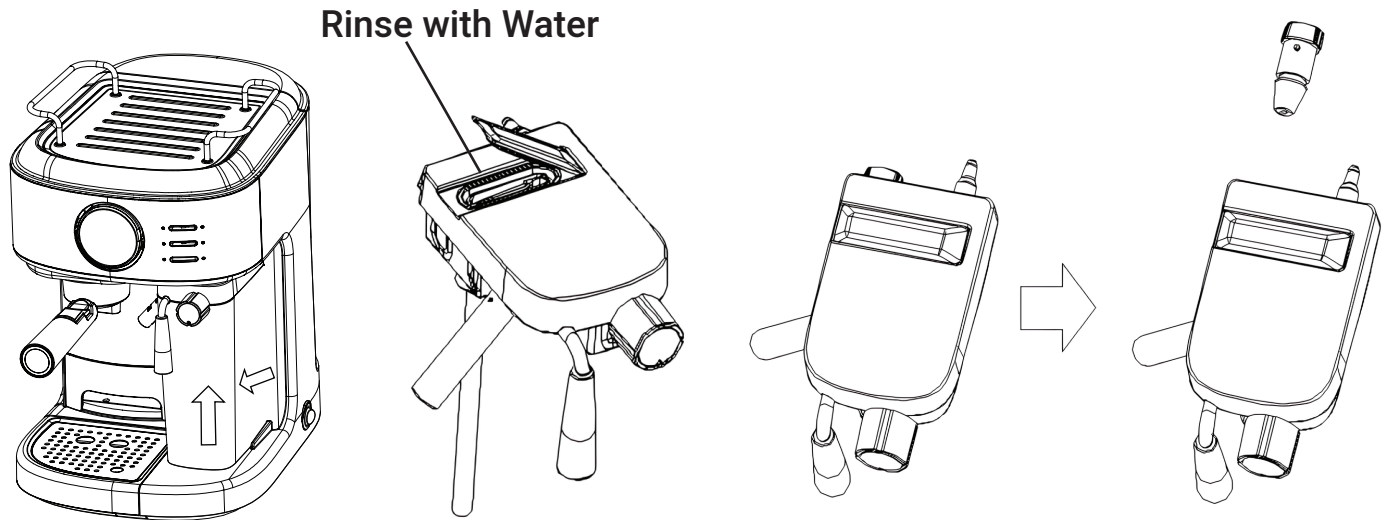

B. Cleaning the Filter

1. Turn the power button on the side of the unit to the off position "0" and disconnect the power cord from the electrical outlet.

Caution: Some of the metal parts may still be hot. Refrain from touching them until they have cooled down.

2. Remove the porta-filter and dispose of the coffee grounds or used pod. Clean both the porta-filter and filter with warm soapy water, ensuring thorough rinsing.

3. Do not wash the filter and filters in the dishwasher.

4. Use a damp cloth or paper towel to wipe the lower part of the brew head in the unit, removing any residual coffee grounds.

5. Reinsert the porta-filter (without any filter) back into the brew head in the unit.

6. Position an empty large cup beneath the porta-filter.

7. Press the espresso button once and allow the unit to brew with water only until it stops automatically.

C. Cleaning the Water Reservoir

1. Empty the water reservoir by removing it and turning it upside down over the sink.
2. It is advisable to wash the reservoir with soapy water, rinse thoroughly, and wipe it dry after each use.
3. The water reservoir is also dishwasher safe.

D. Cleaning the Unit

1. Clean the housing with a soft, damp cloth.
2. Avoid using abrasive cleaners or scouring pads, as they may scratch the finish.
3. Do not store the porta-filter in the brew head. This can negatively impact the seal between the brew head and the porta-filter during espresso extraction.

Important Caution: Do not immerse the appliance in water.

4. Store the porta-filter and filter as illustrated in the figure below.

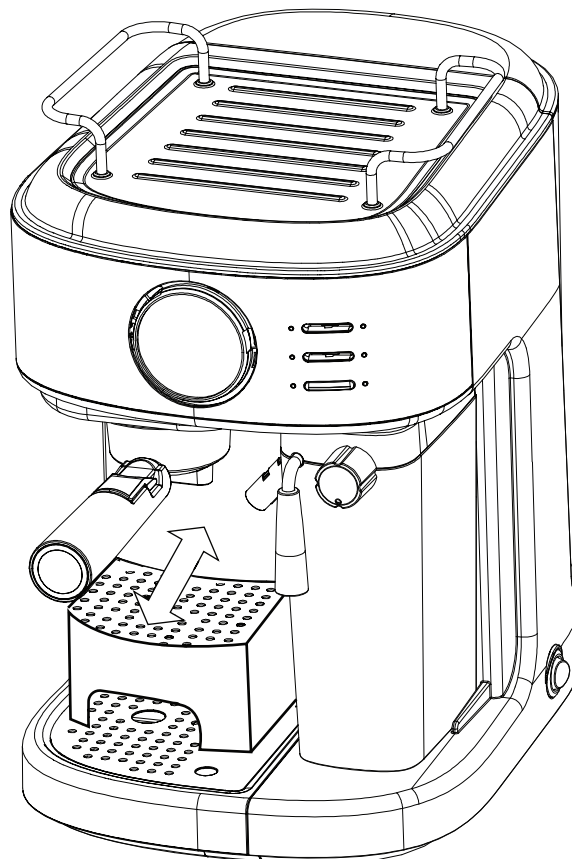

Delimiting

Notes:

1. Mineral deposits build-up in the unit can impact the appliance's operation.
2. The appliance must be delimed when you begin to notice an increase in the time required to brew espresso, or when excessive steaming occurs.
3. You may observe a build-up of white deposits on the surface of the brew head.
4. The frequency of cleaning depends on the hardness of the water used. The following table provides the suggested cleaning intervals.

Suggested Cleaning Intervals	
Type Of Water	Cleaning Frequency
Soft Water (Filtered Water)	Every 80 Brew Cycles
Hard Water (Tap Water)	Every 40 Brew Cycles

A. To Delime the Water Reservoir

1. Fill the reservoir with fresh, undiluted white household vinegar.
2. Allow the appliance to sit overnight with the vinegar solution in the water reservoir.
3. Discard the vinegar by removing the reservoir and turning it upside down over the sink.
4. Rinse the water reservoir thoroughly with tap water by filling the tank halfway with water and then pouring the water back out into the sink. Repeat this step twice.

B. To Delime Internal Parts

1. Ensure you delime the inside of the water reservoir first by following

the “Deliming” steps outlined above.

2. Switch the power button to the “Off” position and ensure the power cord is disconnected from the electrical outlet. Fill the reservoir with white vinegar above the minimum level.
3. Insert the porta-filter (with the filter and without coffee) and place a jar, carafe, or regular cup on top of the drip tray and under the porta-filter.
4. Connect the power cord to the electrical outlet.
5. Turn on the unit by pressing the power button. Once the six control panel lights turn solid blue, press the Espresso Button twice. The vinegar will begin to flow through the unit and will stop automatically.
6. Position a pitcher or large cup (with at least 325 ml/11-ounce capacity) under the tube. Fill the milk reservoir with water and reinstall it. Rotate the Froth control knob to the clean position “”, then press and hold the Latte Button for 3 seconds to activate the cleaning function. Allow the unit to dispense the water through the tube for about 30 seconds, then press the Double Latte Button once to stop the process.
7. Repeat steps 1 through 6 as necessary, using only tap water to rinse any remaining traces of vinegar out of the machine.

C. Manual Descaling

After the unit completes 500 cycles, it will activate a descaling alert, causing the Cappuccino and Latte indicators to blink alternately. If the unit is not descaled in a timely manner, the waterway system may become obstructed.

Note: If you wish to descale before reaching 500 cycles, you can perform a manual descale using the following steps.

Instructions for Use

1. Ensure the power switch is in the “Off” position, and the power cord

is unplugged. Fill the unit with 400ml of white vinegar and 600ml of water in the water tank. Assemble the milk tank into the unit and turn the frothing control knob clockwise to the clean position.

2. Turn the power switch to the "On" position. The Cappuccino and Latte indicators will blink alternately. Press the Espresso and Latte buttons simultaneously; the unit will then enter descaling mode. The six indicators will blink in a circular motion clockwise, and the frothed milk dispensing tube will emit hot water and steam. After 10 minutes, the unit will switch to standby mode, and the six indicators will light up.

3. Remove and discard the residual descaling solution, and clean the water tank. Refill it with an appropriate amount of pure water. Brew two cups of Espresso continuously, then two cups of Latte; once the six indicators illuminate, the cleaning is complete, and the unit will return to standby mode. After the unit completes another 500 cycles, it will activate the descaling reminder again.

Note: Even under descaling reminder status, you can still operate the unit normally. After operation, it will return to the descaling reminder status.

Troubleshooting

Problem	Cause	Solution
Coffee does not come out.	<ol style="list-style-type: none"> 1. No water in the reservoir. 2. Coffee grind is too fine. 3. Too much coffee in the filter. 4. Appliance was not turned on or plugged in. 5. Coffee has been tamped/ compressed too much. 	<ol style="list-style-type: none"> 1. Add water to the reservoir. 2. Use a medium grind for the coffee. 3. Fill the filter with less coffee. 4. Ensure the unit is plugged in and turn it on. 5. Refill the filter basket with coffee, avoiding over-tamping.
Coffee leaks around the edge of the porta-filter.	<ol style="list-style-type: none"> 1. Porta-filter not rotated to full lock position. 2. Coffee grounds around the filter basket rim. 3. Too much coffee in the filter. 	<ol style="list-style-type: none"> 1. Rotate the filter holder to the full lock position. 2. Clean any coffee grounds from the rim. 3. Use less coffee in the filter.

Milk is not foamy after frothing, or it does not come out of the frothing tube.	<ol style="list-style-type: none"> 1. Ran out of steam. 2. Milk is not cold enough. 3. Frothing tube is blocked. 	<ol style="list-style-type: none"> 1. Ensure there is enough water in the reservoir. 2. Chill the milk and frothing pitcher before making cappuccino. 3. Follow the cleaning instructions for the milk reservoir and frothing tube.
Coffee is dispensed too quickly.	<ol style="list-style-type: none"> 1. Ground coffee is too coarse. 2. Not enough coffee in the filter. 	<ol style="list-style-type: none"> 1. Use a finer grind of coffee. 2. Increase the amount of coffee used.
Coffee is too weak.	<ol style="list-style-type: none"> 1. Using small filter for double shot of espresso. 2. Ground coffee is coarse. 	<ol style="list-style-type: none"> 1. Use the large filter for a double shot of espresso. 2. Use a finer grind of coffee.
The three control panel lights are flashing alternately.	Water tank is out of water.	Ensure the water tank is filled.

Disposal

You can help protect the environment! Please remember to comply with local regulations: dispose of non-working electrical equipment at an appropriate waste disposal center.

Warranty

Products that you buy directly from our **LePresso** website or shop come with a 24-month warranty.

The 24-month warranty applies to products purchased directly from our **LePresso** website or store. If **LePresso** products are bought from any of our verified retailers, then the product is eligible for only a 12-month warranty. To extend your product's warranty, visit our website <https://www.lepresso.com/warranty> and fill in your details in the provided form along with an uploaded picture of the product to process your request. Once approved, you will receive a confirmation email of the extended product warranty. Upload the required information within 48 hours of purchase to be eligible for a 24-month warranty period.

For more info, please check:

<https://www.lepresso.com/warranty>

Contact Us

If you have any questions or concerns about our Shipping and Returns Policy, please contact us at: info@lepresso.com

Website: <https://www.lepresso.com/>

Instagram: [lepresso_official](#)