

PORODO



Porodo

Android TV Box Video Streaming

SKU: PD-ATVBTD

Table of Contents

Features	2
Specifications	2
Safety Precautions	2
Installation Method	3
Connection Instructions	4
Package Contents	4
Troubleshooting	4
Warranty	5
Contact Us	5

Before installing and using the product, please carefully read this User Manual to guarantee correct usage and keep it secure for future reference.

Features

Quad-Core Processor: Enhances the box's multitasking abilities, ensuring smooth operation and quick response times during streaming.

USB Flash & Connectivity: Offers versatile connectivity options for external storage and accessories through USB ports, enabling direct media play and expanded device functionality.

Dual-Band WiFi (5/2.4 GHz): Provides flexible and faster internet connections by supporting both 2.4 GHz for wider coverage and 5 GHz for high-speed streaming.

1080p Full HD: Delivers crystal-clear, high-definition visuals, optimizing the viewing experience for all your HD content.

Specifications

CPU	Hi3798M, Quad-core ARM Cortex A53
GPU	Mali450, OpenGL ES 2.0/1.1, OpenVG 1.1
RAM	1GB
Storage	8GB
Connectivity	RJ45, Wi-Fi 5 & 2.4 GHz
Power Plug	UK 3-Pin Plug
Interface	HDMI, x2 USB 2.0, RJ45, AV Output

Safety Precautions

1. Ensure the device remains in a horizontal position during use.
2. Utilize the power adapter provided with the device.
3. Position the device away from heat sources to prevent potential damage.

4. Maintain the device in a well-ventilated area.
5. Keep the device clear of damp and dusty environments to mitigate the risk of fire and electrical shock.
6. Immediately shut down the device and disconnect the power adapter if smoke appears or a burning odor is detected.
7. Disconnect the power adapter if the device is not in use for a prolonged period.
8. Refrain from placing heavy objects on top of the device.
9. Avoid inserting the power adapter with wet hands.
10. Do not disassemble or alter the device yourself.
11. Prevent any shocks or impacts that could damage the device.
12. Avoid using a damaged power cable and plug.

Installation Method

Please consult the images and accompanying instructions below to properly connect your TV, power, network, and other devices.

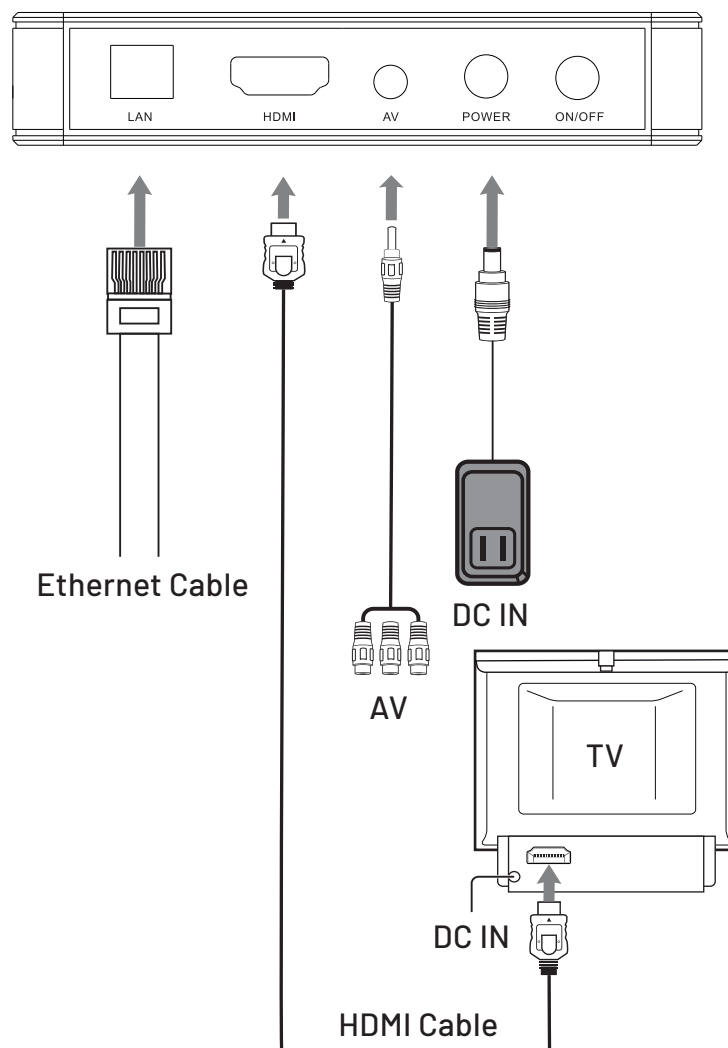

Connection Instructions

1. Connect the HDMI/AV cable to the HDMI/AV port of the TV box and the television set.
2. Attach the power adapter to the Android TV box.
3. Network Connection:
 - A. For a wireless WIFI connection, navigate to System Settings > Network Settings > Wireless Network, select your WIFI SSID, and enter the correct password to establish a connection.
 - B. For an Ethernet connection, insert the Ethernet cable into the LAN port of the Android TV box and the corresponding LAN port of the router or the Ethernet port of your home broadband network.

Package Contents

The package includes the following accessories:

Android TV Box
Power Adapter

Remote Control
HDMI Cable

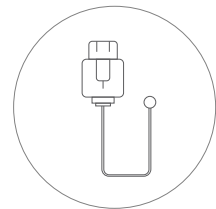
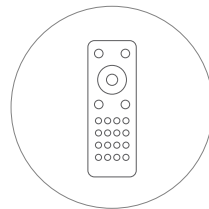
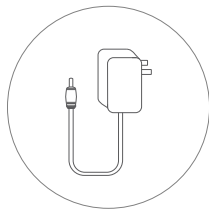
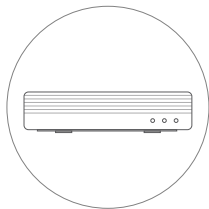

Android TV Box

Power Adaptor

Remote Control

HDMI Cable

Troubleshooting

1. The TV has no display or signal

Ensure that the power plug is connected and that the electrical outlet is supplying normal voltage. Verify the HDMI/AV cable is properly connected and switch the TV's signal input to the appropriate source.

2. TV with images but without sound or with low volume

Confirm that the audio cable is correctly connected. Make sure the volume on your box or TV is not set to mute or too low. If necessary, increase the volume.

3. Failed to connect to the network

Please reconnect to the internet. Check if the Wi-Fi is turned off or if the signal is too weak. Restart the Wi-Fi or adjust the position of the router.

4. Controller failure

Ensure you are using the remote control in the correct direction. Remember to change the batteries when the remote control is low on battery power.

Warranty

Products that you buy directly from our **Porodo** website or shop come with a 24-month warranty.

When you buy **Porodo** products from any of our approved sellers, you only get a 12-month warranty. If you want to extend this warranty, go to our website at **porodo.net/warranty** and fill out the form with your information. Don't forget to upload a picture of the product too. After we've checked and accepted your request, we'll send you an email to confirm that your product's warranty has been extended.

For more info, please check:
porodo.net/warranty

Contact Us

If you have any questions about this Privacy Policy, please contact us at:

info@porodo.net

Website: **porodo.net**

Service Support: **support@porodo.net**

Instagram: **[porodo](https://www.instagram.com/porodo)**